

PDA10CS Operating Manual - Switchable Gain, Amplified InGaAs Detector

Description:

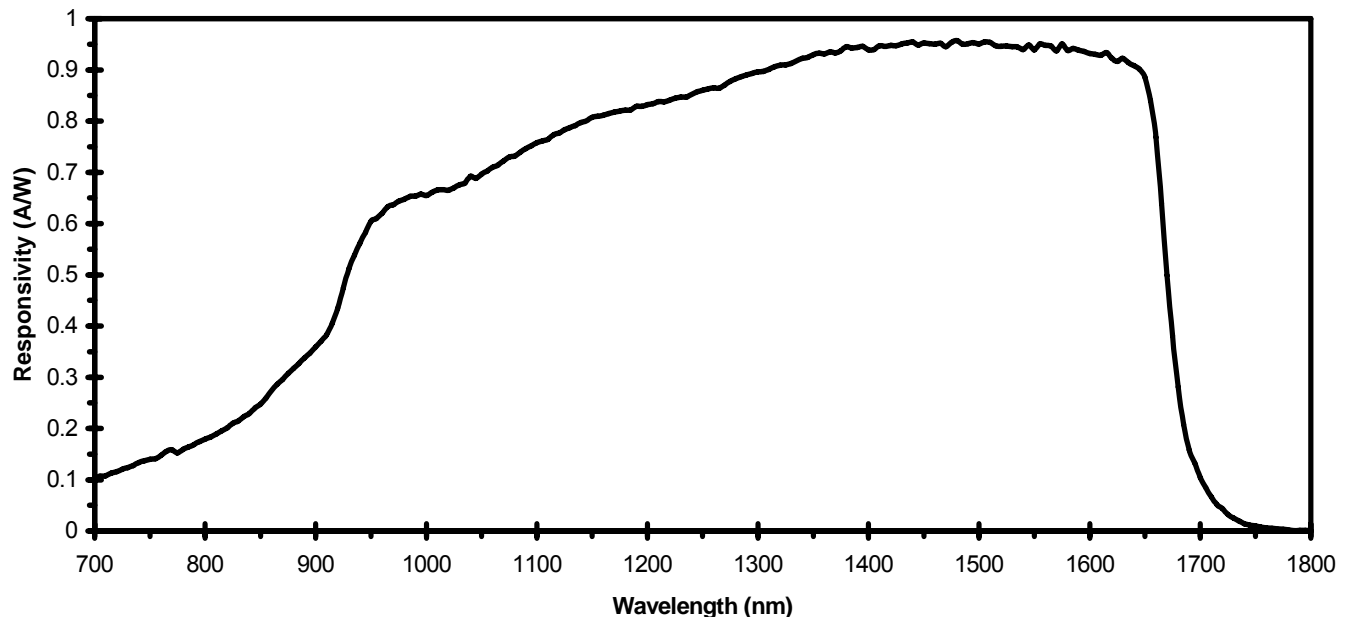
The PDA10CS is an amplified, switchable-gain, InGaAs detector designed for detection of light signals over 700 – 1800nm wavelength range. An eight-position rotary switch allows the user to vary the gain in 10 dB steps. A buffered output drives 50Ω load impedances up to 5 volt. The PDA10CS housing includes a removable threaded coupler (SM1T1) and retainer ring (SM1RR) that is compatible with any number of Thorlabs 1" threaded accessories. This allows convenient mounting of external optics, light filters, apertures, as well as providing an easy mounting mechanism using the Thorlabs cage assembly accessories.

The PDA10CS has two #8-32 tapped mounting holes with a 0.25" mounting depth and includes a 120VAC power AC/DC supply. The PDA10CS-EC has two M4 tapped mounting holes and includes a 230VAC AC/DC power supply.

Specifications:

General Specifications			
Detector:	InGaAs PIN	Gain Switch:	8-Pos Rotary
Active Area:	Ø1mm (0.8mm ²)	On / Off Switch:	Slide
Surface Depth:	0.07" (1.9mm)	Output:	BNC
Wavelength Range:	700-1800nm	Optical Head Size:	2.76" x 2.08" x 0.83" 70.1 x 52.8 x 21.1mm
Peak Wavelength (λ_p):	1550nm	Weight ³ :	0.15 / 2.1lbs
Peak Response:	0.95 A/W @ λ_p	Accessories:	SM1T1, SM1RR
Output Voltage ¹ (50Ω):	0-5V	AC Power Supply:	AC-DC Converter
(Hi-Z):	0-10V	Power Supply	31W
Output Impedance:	50Ω	Input Power ⁴ :	100-120VAC, 50-60Hz (220-240VAC -EC)
Max Output Current:	100mA	Storage Temp:	-55 to 125 °C
Load Impedance:	50Ω – Hi-Z	Operating Temp:	0 to 40 °C
Gain Adj. Range:	70dB		
Gain Steps:	8x 10dB steps		

Figure 1 – PDA10CS Spectral Responsivity



Performance Specifications			
0dB Setting		40dB Setting	
Gain ¹ (Hi-Z):	1.51 x 10 ³ V/A ±2%	Gain ¹ (Hi-Z):	1.51 x 10 ⁵ V/A ±2%
(50Ω):	0.75 x 10 ³ V/A ±2%	(50Ω):	0.75 x 10 ⁵ V/A ±2%
Bandwidth:	17MHz	Bandwidth:	320kHz
Noise (RMS):	600μV	Noise (RMS):	300μV
NEP (@ λ _p):	6 x 10 ⁻¹¹ W/√Hz	NEP (@ λ _p):	1.4 x 10 ⁻¹² W/√Hz
Offset:	5mV (10mV max)	Offset:	10mV (20mV max)
10dB Setting		50dB Setting	
Gain ¹ (Hi-Z):	4.75 x 10 ³ V/A ±2%	Gain ¹ (Hi-Z):	4.75 x 10 ⁵ V/A ±2%
(50Ω):	2.38 x 10 ³ V/A ±2%	(50Ω):	2.38 x 10 ⁵ V/A ±2%
Bandwidth:	8.5MHz	Bandwidth:	90kHz
Noise (RMS):	320μV	Noise (RMS):	475μV
NEP (@ λ _p):	1 x 10 ⁻¹¹ W/√Hz	NEP (@ λ _p):	1.5 x 10 ⁻¹² W/√Hz
Offset:	6mV (12mV max)	Offset:	15mV (40mV max)
20dB Setting		60dB Setting	
Gain ¹ (Hi-Z):	1.5 x 10 ⁴ V/A ±2%	Gain ¹ (Hi-Z):	1.5 x 10 ⁶ V/A ±5%
(50Ω):	0.75 x 10 ⁴ V/A ±2%	(50Ω):	0.75 x 10 ⁶ V/A ±5%
Bandwidth:	1.9MHz	Bandwidth:	33kHz
Noise (RMS):	310μV	Noise (RMS):	850μV
NEP (@ λ _p):	3 x 10 ⁻¹² W/√Hz	NEP (@ λ _p):	1.5 x 10 ⁻¹² W/√Hz
Offset:	6mV (15mV max)	Offset:	20mV (75mV max)
30dB Setting		70dB Setting	
Gain ¹ (Hi-Z):	4.75 x 10 ⁴ V/A ±2%	Gain ¹ (Hi-Z):	4.75 x 10 ⁶ V/A ±5%
(50Ω):	2.38 x 10 ⁴ V/A ±2%	(50Ω):	2.38 x 10 ⁶ V/A ±5%
Bandwidth:	775kHz	Bandwidth:	12 kHz
Noise (RMS):	300μV	Noise (RMS):	1.5mV
NEP (@ λ _p):	1.25 x 10 ⁻¹² W/√Hz	NEP (@ λ _p):	2 x 10 ⁻¹² W/√Hz
Offset:	8mV (15mV max)	Offset:	40mV (200mV max)

Note 1: The PDA10CS has a 50Ω series terminator resistor (i.e. in series with amplifier output). This forms a voltage divider with any load impedance (e.g. 50Ω load divides signal in half).

2: All measurements performed with a 50Ω load unless stated otherwise.

3: Detector Package / Power Supply.

4: Although the power supply is rated for 31W the PDA10CS actual usage is <5W over the full operating range.

Setup

- Unpack the optical head, install a Thorlabs TR-series ½" diameter post into one of the #8-32 (M4 on -EC version) tapped holes, located on the bottom and side of the head, and mount into a PH-series post holder.
- Connect the power supply 3-pin plug into the power receptacle on the PDA10CS.
- Plug the power supply into a 50-60Hz, 100-120VAC outlet (220-240VAC for -EC version).
- Attach a 50Ω coax cable (i.e. RG-58U) to the output of the PDA. When running cable lengths longer than 12" we recommend terminating the opposite end of the coax with a 50Ω resistor (Thorlabs p/n T4119) for maximum performance. Connect the remaining end to a measurement device such as an oscilloscope or high speed DAQ card. **Caution:** Many high speed oscilloscopes have input impedances of 50Ω. In this case, do not install a 50Ω terminator. The combined loads will equal 25Ω which could allow ~135mA of output current. This will damage the output driver of the PDA10CS.
- Power the PDA10CS on using the power switch located on the top side of the unit.
- Install any desired filters, optics, adapters, or fiber adapters to the input aperture. **Caution:** The PDA10CS was designed to allow maximum accessibility to the photodetector by having the front surface of the diode flush with the outside of the PDA housing. When using fiber adapters, make sure that the fiber ferrule does not crash into the detector. Failure to do so may cause damage to the diode and / or the fiber. An easy way to accomplish this is to install a SM1RR retaining ring (included with the PDA10CS) inside the 1" threaded coupler *before* installing the fiber adapter.
- Apply a light source to the detector. Adjust the gain to the desired setting.

Operation

Thorlabs PDA series are ideal for measuring both pulsed and CW light sources. The PDA10CS includes a reverse-biased PIN photo diode, mated to a switchable gain transimpedance amplifier, and packaged in a rugged housing. The thin profile housing allows the PDA10CS to fit into small spaces. All controls and connections are orthogonal to the light path providing easier access and minimizing the light path footprint.

Output

The maximum output of the PDA10CS is 10 volts for high impedance loads (i.e. $R_{LOAD} \geq 5k\Omega$) and 5 volts for 50Ω loads. Adjust the gain so that the measured signal level out of the PDA10CS is below 10 volts (5 volts with a 50Ω load) to avoid saturation. If necessary, use external neutral density filters to reduce the input light level. The BNC output signal is buffered with an amplifier capable of driving 50Ω loads. A 50Ω series resistor is included on the output to impedance match a 50Ω coax cables. For best performance, Thorlabs recommends operating the PDA10CS with a 50Ω terminating load located at the end of the coax cable. While this is not necessary, it eliminates ringing and distortion due to impedance mismatches.

Gain Adjustment

The PDA10CS includes a low noise, low offset, high gain transimpedance amplifier that allows gain adjustment over a 70dB range. The gain is adjusted by rotating the gain control knob, located on the top side of the unit. There are 8 gain positions incremented in 10dB steps. It is important to note that the bandwidth will decrease as the gain increases. See the specifications above to choose the best gain vs. bandwidth for a given input signal.

Light to Voltage Conversion

The Spectral Responsivity, $\mathfrak{R}(\lambda)$, can be obtained from Figure 1 to estimate the amount of output voltage to expect. The light to voltage conversion can be estimated by factoring the wavelength-dependent responsivity of the InGaAs detector with the transimpedance gain as shown below:

$$\text{E.g. 1 – Output [V/W]} = \text{transimpedance gain [V/A]} \times \mathfrak{R}(\lambda) \text{ [A/W]}$$

For low terminating resistors, $>5k\Omega$ or 1% error, an additional factor needs to be included in the above formula. As described above the output includes a 50Ω series resistor (R_S). The output load creates a voltage divider with the 50Ω series resistor as follows:

$$\text{E.g. 2 – Scale Factor} = R_{LOAD} / (R_{LOAD} + R_S)$$

Where R_{LOAD} is the terminating resistor and $R_S = 50\Omega$. For a standard 50Ω terminator, the gain will be scaled by $\frac{1}{2}$ as shown below:

$$\text{Scale Factor} = 50\Omega / (50\Omega + 50\Omega) = 0.5$$

$$\text{E.g. 3 – Output [V/W]} = \text{transimpedance gain [V/A]} \times \mathfrak{R}(\lambda) \text{ [A/W]} \times \text{Scale Factor}$$

Maintaining the PDA10CS

There are no serviceable parts in the PDA10CS optical head or power supply. The housing may be cleaned by wiping with a soft damp cloth. The window of the detector should only be cleaned using isopropyl alcohol and optical grade wipes. If you suspect a problem with your PDA10CS please call Thorlabs and technical support will be happy to assist you.

Contact

Americas

Thorlabs Inc.
435 Route 206 North
Newton NJ 07860
USA
Ph: (973) 579-7227
Fax: (973) 300-3600
www.thorlabs.com
Email: techsupport@thorlabs.com

Europe

Thorlabs GmbH
Gaußstr. 11
85757 Karlsfeld
Germany
Ph: +49 (0) 8131-59-56-0
Fax: +49 (0) 8131-59-56-99
www.thorlabs.com
Email: Europe@thorlabs.com

UK and Ireland

Thorlabs, LTD.
1 Saint Thomas Place, Ely
Cambridgeshire CB7 4EX
Great Britain
Ph: +44 (0) 1353-654440
Fax: +44 (0) 1353-654444
www.thorlabs.com
Email: sales.uk@thorlabs.com

Scandinavia

Thorlabs Sweden AB
Box 141 94
400 20 Göteborg
Sweden
Ph: +46-31-733-30-00
Fax: +46-31-703-40-45
www.thorlabs.com
Email: Scandinavia@thorlabs.com

Japan

Thorlabs Japan, Inc
5-17-1, Ohtsuka
Bunkyo-ku, Tokyo 112-0012
Japan
Ph: +81-3-5977-8401
Fax: +81-3-5977-8402
www.thorlabs.jp
Email: sales@thorlabs.jp

WEEE

As required by the WEEE (Waste Electrical and Electronic Equipment Directive) of the European Community and the corresponding national laws, Thorlabs offers all end users in the EC the possibility to return “end of life” units without incurring disposal charges.

This offer is valid for Thorlabs electrical and electronic equipment

- sold after August 13th 2005
- marked correspondingly with the crossed out “wheelie bin” logo (see fig. 1)
- sold to a company or institute within the EC
- currently owned by a company or institute within the EC
- still complete, not disassembled and not contaminated

As the WEEE directive applies to self contained operational electrical and electronic products, this “end of life” take back service does not refer to other Thorlabs products, such as

- pure OEM products, that means assemblies to be built into a unit by the user (e. g. OEM laser driver cards)
- components
- mechanics and optics
- left over parts of units disassembled by the user (PCB’s, housings etc.).

If you wish to return a Thorlabs unit for waste recovery, please contact Thorlabs or your nearest dealer for further information.

Waste treatment on your own responsibility

If you do not return an “end of life” unit to Thorlabs, you must hand it to a company specialized in waste recovery. Do not dispose of the unit in a litter bin or at a public waste disposal site.

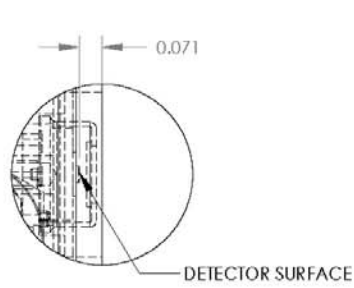
Ecological background

It is well known that WEEE pollutes the environment by releasing toxic products during decomposition. The aim of the European RoHS directive is to reduce the content of toxic substances in electronic products in the future. The intent of the WEEE directive is to enforce the recycling of WEEE. A controlled recycling of end of live products will thereby avoid negative impacts on the environment.

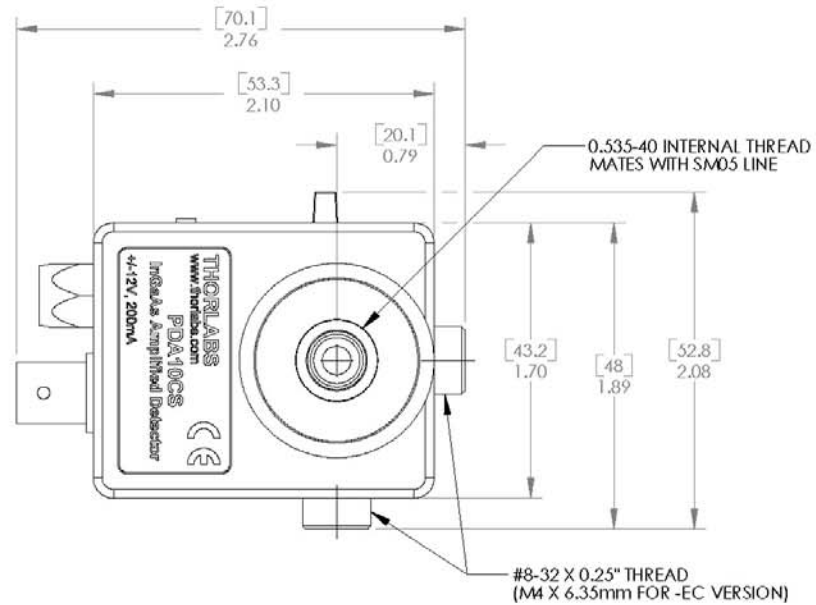
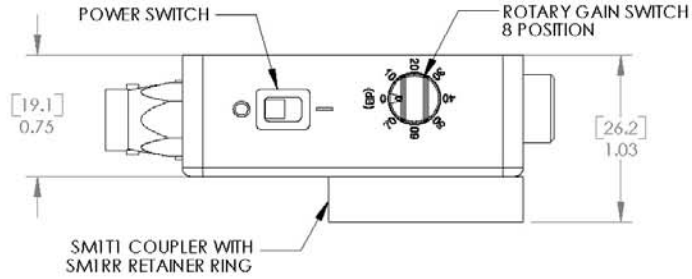
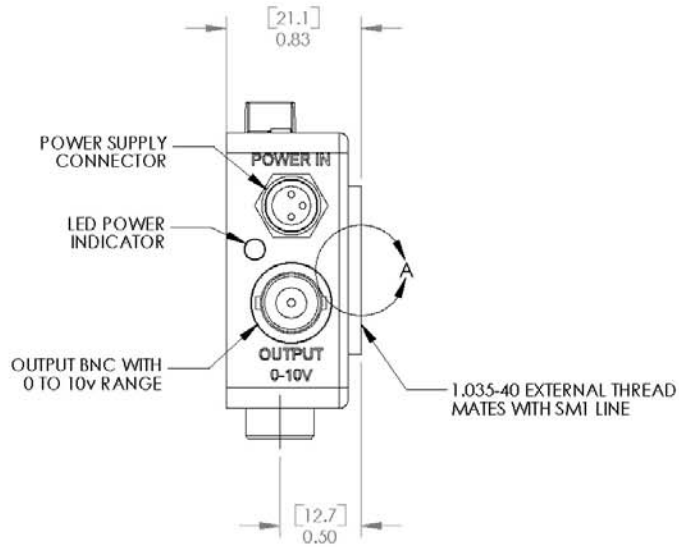


Figure 2. Crossed out “wheelie bin” symbol

COPYRIGHT © 2006 by THORLABS INC.



DETAIL A
SCALE 2:1



TOLERANCES		NAME	DATE
UNLESS OTHERWISE SPECIFIED:		DRAWN	EC 2/22/06
DIMENSIONS ARE IN INCHES		ENG APPR.	EC 2/22/06
LINEAR TOLERANCES:		MFG APPR.	EC 2/22/06
TWO PLACE DECIMAL: ±0.010		PROPRIETARY AND CONFIDENTIAL	
THREE PLACE DECIMAL: ±0.005		THE INFORMATION CONTAINED IN THIS	
ANGULAR: ±30'		DRAWING IS THE SOLE PROPERTY OF	
SURFACE FINISH: 32 MICROINCHES		THORLABS, INC. ANY REPRODUCTION	
PARALLELISM: 0.002		IN PART OR AS A WHOLE WITHOUT	
FLATNESS: 0.002		THE WRITTEN PERMISSION OF	
STRAIGHTNESS: 0.002		THORLABS, INC. IS PROHIBITED.	
CONCENTRICITY: 0.002			
PERPENDICULARITY: 0.002			
THREAD: CLASS 2 FIT			

THORLABS INC.		PO BOX 366 NEWTON NJ	
TITLE: InGaAs AMPLIFIED DETECTOR			
MATERIAL: PDA10CS		SIZE A	REV. A
SCALE: 1:1		SHEET 1 OF 1	
DWG. NO. 13058-E01	PART NO. PDA10CS		

5

4

3

2

1